

CAPACITY	SYMBOL/SERIAL NO.	CIRCUIT DIAGRAM
AC100-240V, 50/60Hz		
12.5W x 2		

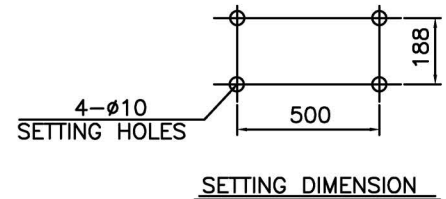
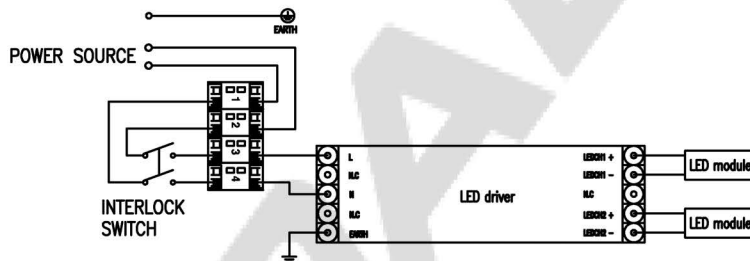
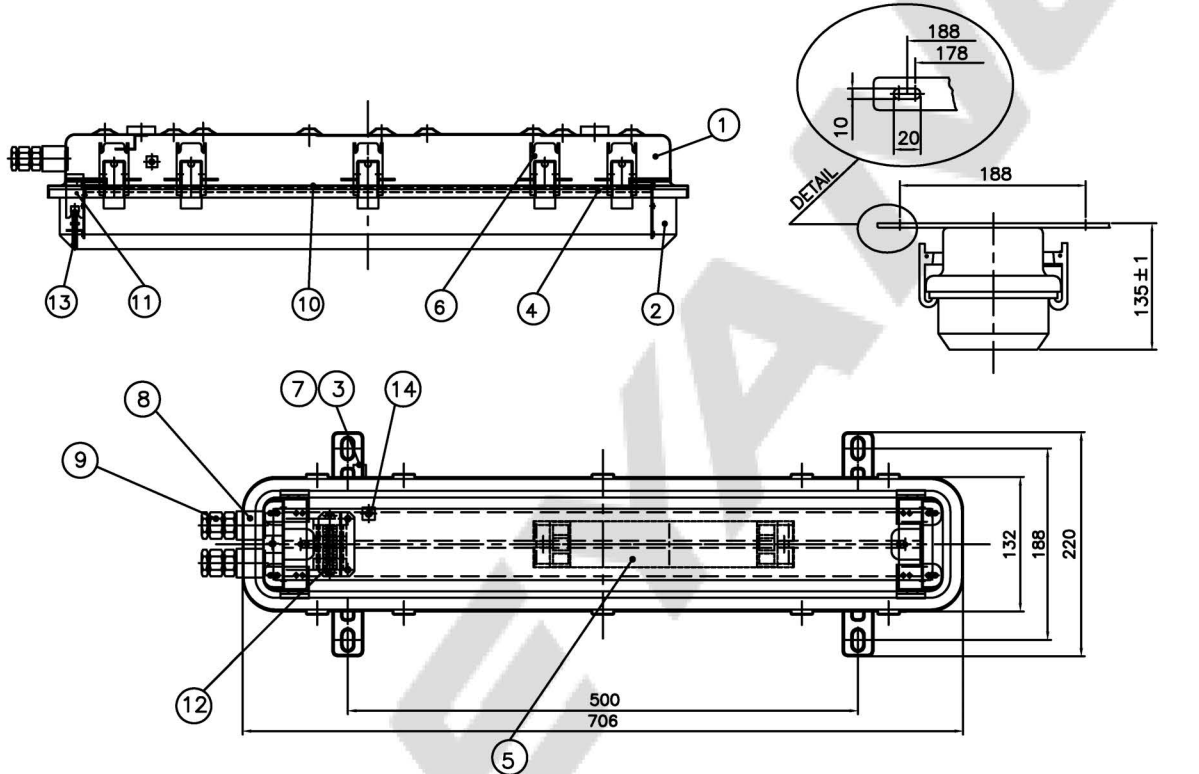

CIRCUIT DIAGRAM

SETTING DIMENSION

14	INSIDE EARTH BOLT	STAINLESS STEEL316	1		7	OUTSIDE EARTH BAR	STAINLESS STEEL316	1	
13	INTERLOCK SHAFT	BRASS	1		6	LATCH	STAINLESS STEEL316L	10	
12	TERMINAL BLOCK	-	1	CLAMPING 4P	5	LED driver	-	1	
11	INTERLOCK SWITCH	-	1		4	LED module	-	2	5,000±300K
10	REFLECTOR	STEEL	1		3	OUTSIDE EARTH BOLT	STAINLESS STEEL316	1	M6
9	CABLE GLAND(M20)	BRASS	2	OS-E1UF 16 (ø9~15.5)	2	GLOBE	POLYCAR-BONATE	1	
8	GLAND HUB(M20)	STAINLESS STEEL316	2		1	BODY	STAINLESS STEEL316L	1	
NO	NAME OF PART	MATERIAL	Q'TY	REMARKS	NO	NAME OF PART	MATERIAL	Q'TY	REMARKS

APPROVED	B. K. KIM	UNIT	MM	TITLE: INCREASED SAFETY LED CEILING LIGHT (Ex db eb mb op is IIC T4 Gb) FOR MARINE USE					
CHECKED		SCALE	N/S						
DESIGN	B. I. KIM	COLOR	N-9.3						
DATE	2015.12.04	IP	66/67						
				MODEL NO.	EXLED-125ed-550UWM16UF2HC50-R10	WEIGHT	6.3 Kg		
				DWG NO.	L71370167	SHEET NO.	12		